



# Battery Cell Simulator

# THE VIRTUAL BATTERY

The comemso battery cell simulator – the all-in-one battery management system test and development solution for (mobile) energy storage systems.



**INNOVATION AWARDS BW 2013**  
 Innovation Award Baden-Württemberg  
 Dr.-Rudolf-Eberle-Preis  
 Award Winner 2013

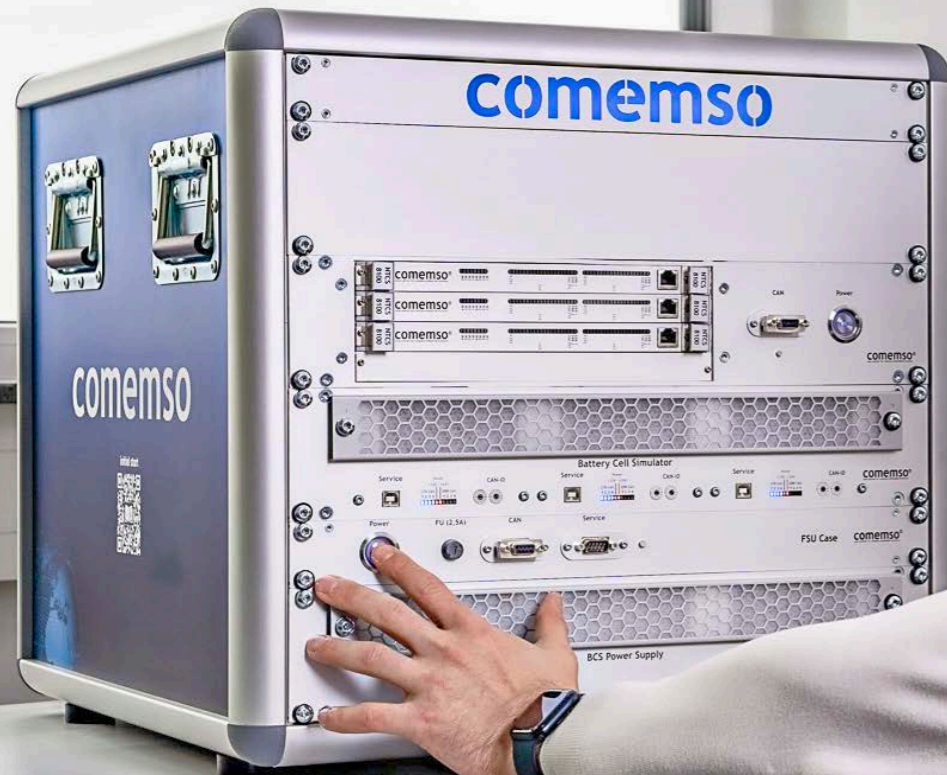

## BATTERY CELLS NEED CONSTANT MONITORING

Electromobility is growing at a tremendous rate worldwide. For today's mobile energy storage systems, that means they not only have to deliver high performance, they also need to ensure safe, reliable operation. Doing so requires constantly monitoring the voltage and temperature of every single battery cell. This is done with a special electronic monitoring system called the cell management controller (CMC).

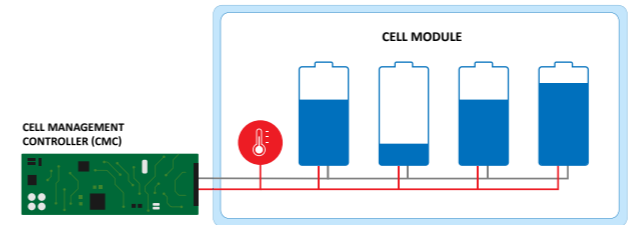

Fig. 1 Cell management

Individual battery cells are combined into cell modules, and each cell module has its own CMC (Fig. 1). The cell management controller is an electronic component that has one or more micro-controllers and is specially designed for monitoring battery cells. The CMC is connected via measuring leads to the positive and negative poles of the cells so it can measure the voltage reliably. It is also connected to temperature sensors, which are indispensable for optimizing battery loads and efficiency.

## BALANCE

Since the cell modules consist of multiple single cells connected in series, their internal resistance can vary greatly due to a wide range of factors such as variations in produc-

tion quality or age-related fatigue. This can lead to different charging and discharging curves, resulting in critically deep discharge of the battery cells or, during charging, in the charge cut-off voltage being exceeded even though the overall voltage is still in the nominal range. Depending on the type of battery, this can lead to irreparable damage or even combustion of the battery modules!

If deviating charge levels occur (Fig. 1), the charge levels of the individual battery cells can be adjusted to match each other with an equalizing system. This process is called balancing. The equalizing system involves an electronic circuit that is normally an integral part of any battery management system and controls the uniform charging of the individual battery cells in a cell module. It uses the voltage to determine the charging level, which is called state of charge (SoC). In addition, the temperature of each cell, which depends on the chemical process involved in charging and discharging, is measured.

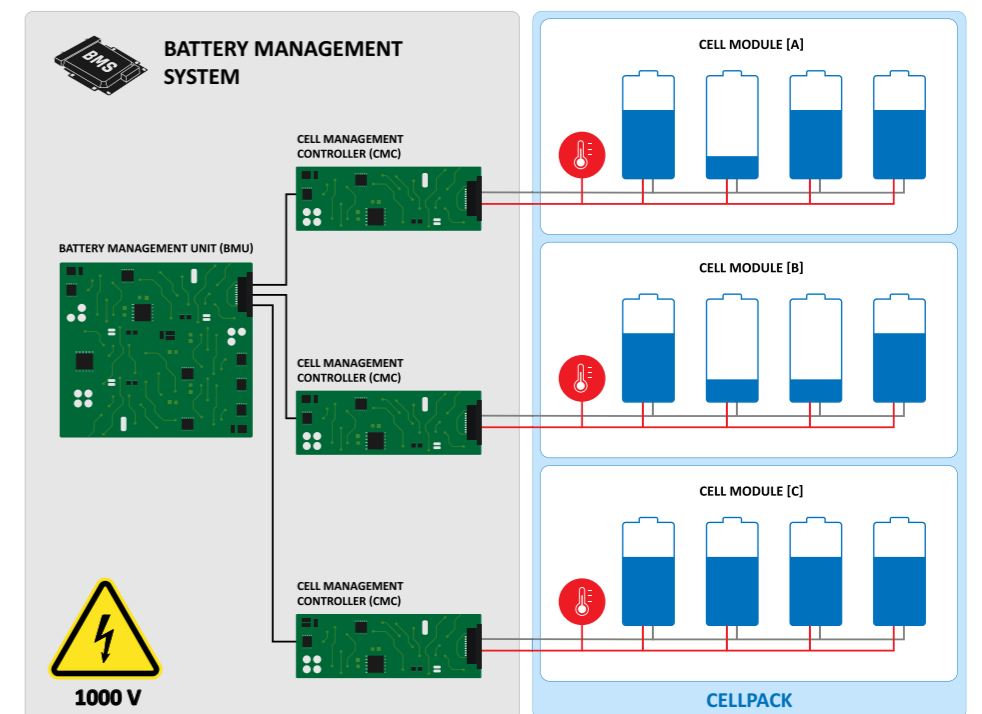

Fig. 2 Battery management

## THE CONTROL CENTER

The battery management system (BMS) includes the battery management unit (BMU) and all cell management controllers (Fig. 2). The BMU is the central control unit for battery modules such as those used to drive electric vehicles or all other kinds of energy storage systems. It acts as the “brain” where all of the information collected by the battery monitoring systems comes together. Using the battery cell voltages, it determines the current states of charge (SoC) and controls the overall communication between the battery and the vehicle. When necessary, it also gives the command to perform balancing so that the battery cells are not deep-discharged or overcharged as described above.

In battery-powered vehicles, it is supplied with voltage from the vehicle’s 12- or 24-volt electrical system, so it has no effect on the range when the vehicle is at rest.

In contrast, the cell management controllers are generally supplied with electricity from the vehicle battery and thus cause slight charge losses. This makes it important, when developing a CMC, to ensure that its energy consumption is kept as low as possible and to implement a rest mode to minimize “self-discharging”.

## BALANCING: PASSIVE AND ACTIVE

When the cell voltages are not all equal, the full cell pack ceases charging once a cell reaches an SoC of 100%. At this point and no later, balancing must be initiated. This involves discharging a fully charged cell to the level of the other cells so that all of the cells can then be charged together.

There are two types of balancing: passive and active. In passive balancing, resistance is applied according

to an algorithm to the cells with the highest SoC. These cells are then charged at a much lower rate, or are even discharged. The other incompletely charged battery cells in the series circuit continue to receive the full charging current until the SoC is balanced. This method is easily implemented and thus economical. However, it causes energy to be converted to heat, which reduces efficiency.

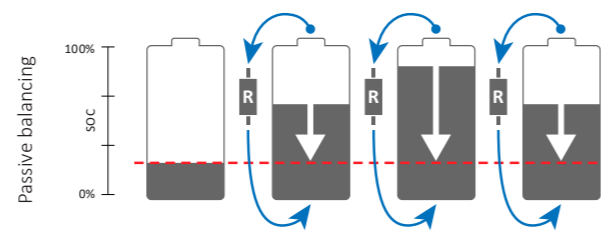

In active balancing, charge is exchanged among the battery cells, a process that is controlled by the BMU. In this process, energy is transferred from cells that are already fully charged to those neighboring battery cells that have not yet reached their SoC. There are three methods: a) semiconductor switching (e.g. matrix with transistors), b) capacitive charge transfer, and c) inductive charge transfer.

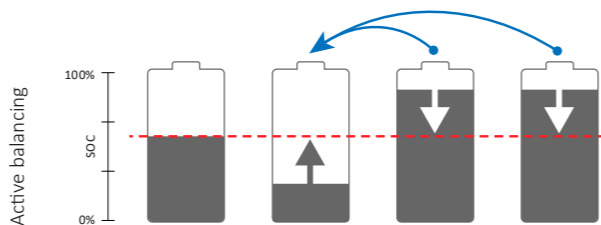

The advantage here is greater efficiency since only a small portion of the energy is converted to heat. However, active balancing involves more circuitry, which results in higher development and hardware costs.

## VIRTUAL BATTERY CELLS

Since the conditions for testing real batteries are dangerous, unreproducible and not automatable, the validation of battery management systems calls for configurable “virtual battery cells”.

These virtual battery cells have been implemented

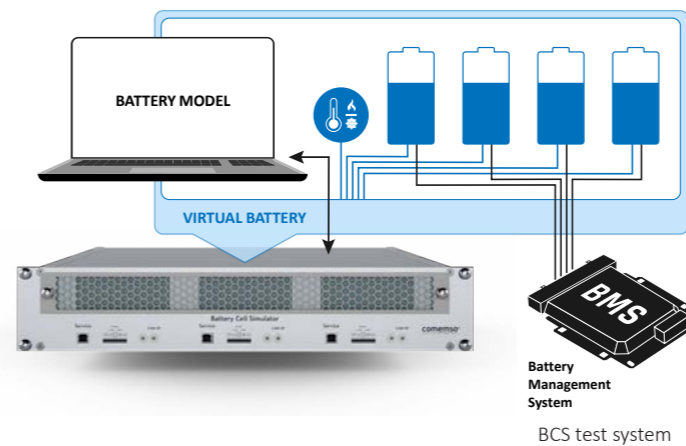

in the battery cell simulator: Since all of their electrical characteristics can be parameterized, they can simulate all required states and faults for the battery management system.

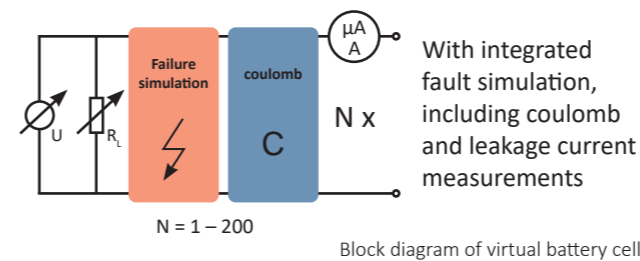

High-precision ammeters between the cell inputs on the BMS and the cell outputs on the cell modules are used to measure quiescent current and detect unwanted leakage current, which could occur due to faulty BMS outputs or incorrect software control. This leakage current measurement enables early detection of errors during deactivation of the BMS, preventing deep discharge and damage to the battery cells. In addition, the temperature sensors on the cells

are replaced by suitable galvanically isolated temperature sensor emulators, the NTC/PTC sensor simulation. All data signals from the individual cell modules can then be fed into the test bench or hardware-in-the-loop system (HiL system). The battery cells and temperature sensors from comemso emulate the real functionality so the BMS can be operated in the lab. In addition, fault simulation can be used to generate faulty system states so that component malfunctions and their detection can be verified in the lab. This capability makes a comemso battery cell simulator a key test unit for verifying all BMS functionality.

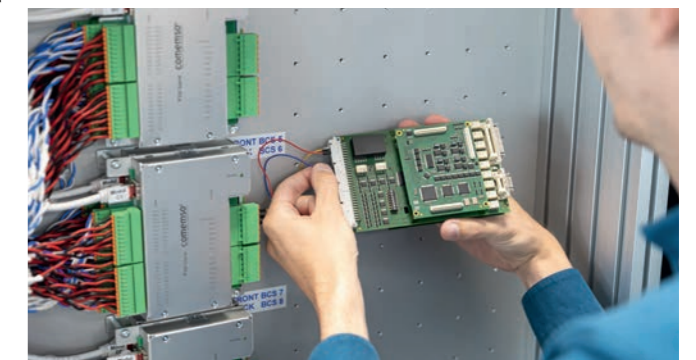

## APPLICATIONS

Typical users of a battery cell simulator include developers of algorithms for passive and active balancing, developers of battery management systems, manufacturers of chips for battery management systems, manufacturers of energy storage systems and vehicles who want to verify functionality before BMS integration in series production, and test and certification labs.

## FOR THE HIGHEST STANDARDS

A battery cell simulator (BCS) must be capable of performing functional verification for many different aspects of a modern BMS and needs to provide high-precision voltage regulation even at high balancing currents so that it can accurately emulate the state of charge of a battery cell. It also needs well-matched hardware and software controls for high accuracy, with lean control algorithms that allow no overshoots while ensuring equally dynamic and safe performance.

### FROM THE MARKET LEADER

comemso uses only high-quality circuitry components in its battery cell simulators to ensure optimal noise suppression and output signal smoothing and to enable the verification of passive and active balancing for the current range up to 6.5 A, while quiescent and leakage currents are measured in the  $\mu\text{A}$  range. The balancing algorithms are validated using full-range mA

measurements or the coulomb measurement. Depending on the selected version, integrated fault simulation allows short circuits, open circuits, reversed polarity or incorrectly installed cells to be simulated.

Thanks to the high degree of insulation for each cell, the total voltage of the battery cell simulator can be as high as 1000 V, making it possible to implement batteries with up to 200 cells of 5 V each.

The comemso BMS test bench meets all of these requirements, making it a reproducible and reliable application for the complete functional verification of modern BMS systems (i.e. for software and hardware). All parameters such as voltage supply, current strength and current sinks can be freely calibrated, making the comemso test systems future-proof.

## DESIGN OF A BMS TEST BENCH

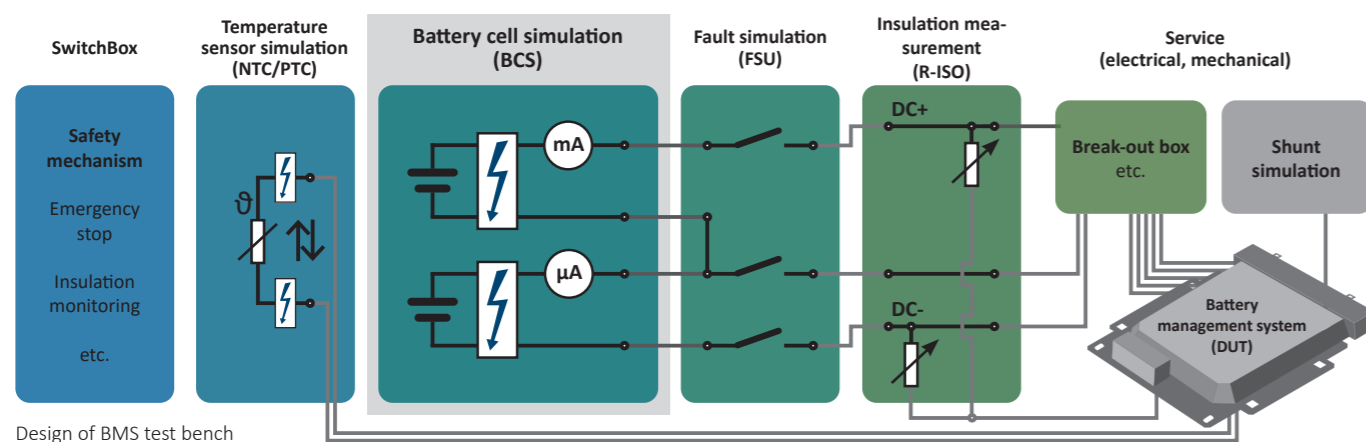

A complete HiL test bench for BMS tests consists of many modular components and can be tailored to your needs. It can also be expanded in the future.

You can start with a BCS with only a few cells and add more cells and functionality later.

## COMEMSO BATTERY CELL SIMULATOR EXAMPLE WITH 96 VIRTUAL BATTERY CELLS

Sophisticated **safety concept** with upgradable emergency stop circuit

Test processes can be **controlled with an external PC** via CAN or EtherCAT

Completely **scalable** systems with a wide range of features

Each **BCS module** simulates 12 battery cells

High reliability and robust design with a **3-year guarantee**

**LED status lights** for quick status identification

**Sturdy castors** for flexible positioning in lab

**Customer-specific adaptations** with flexible external connections

Direct connection to the **device under test (DUT)** with cable sets for optimum precision and minimum interference

Battery management system

**BATTERY MODEL**

## INTEGRATED FAULT SIMULATION

For best results and precise cell voltage, fault simulation is integrated in the BCS electronics of every cell.

### 1. DISCONNECTIONS

Cable breaks in the connection between cells and BMS, material fatigue, etc.

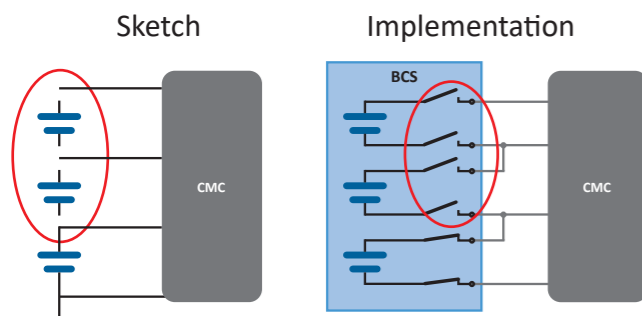

### 2. SHORT CIRCUITS

Faulty battery cells, cell control errors, defective electronic components, etc.

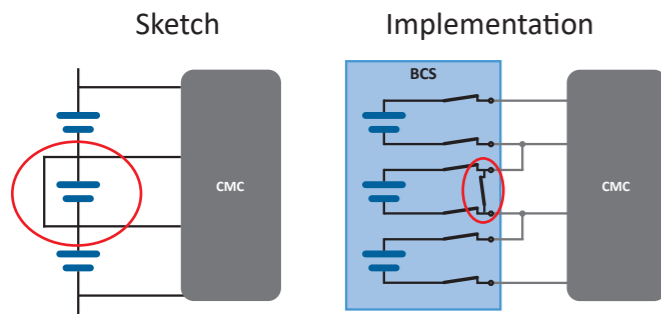

### 3. REVERSED POLARITY

Cabling errors, reversed polarity in a cell, etc.

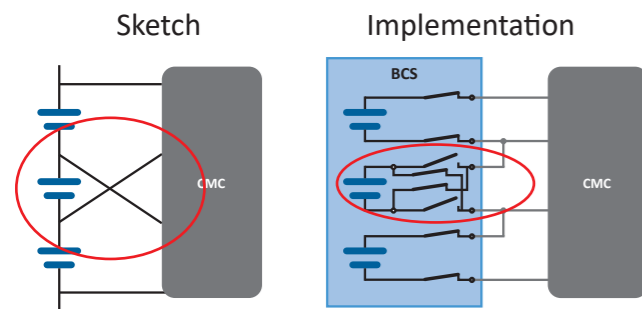

## PRECISION IS INDISPENSABLE

Measurement errors play a key role when the state of charge of the cells in a battery pack is being determined. Even inaccuracies of  $\pm 10$  mV hamper active charge balancing. Cell measurement accuracy depends on the CMC's voltage reference. The simplified discharge curve depicted here shows how important precise cell voltage measurement is.

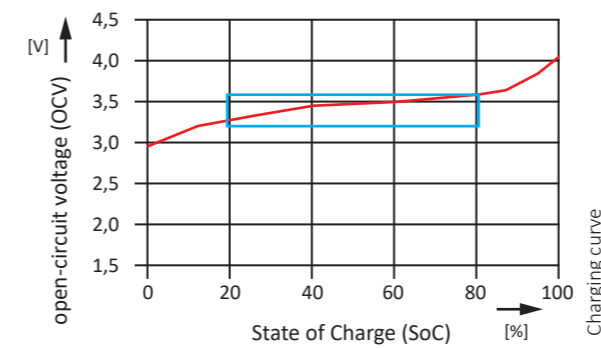

and follows a relatively linear path. In the illustration, 20% corresponds to approximately 3.25 V and 80% to approximately 3.6 V. Between 20% and 80% SoC (60%) there is thus a difference of 0.35 V (350 mV). If we want to measure the SoC for every single percent, we would have to calculate it as follows:

$$1\% \text{ SoC} = \frac{350 \text{ mV}}{60\% \text{ SoC range}} = 5.82 \text{ mV}$$

According to the sampling theorem, the CMC should measure the voltage with twice the precision, i.e. 2.9 mV. To enable this degree of measurement precision for the CMC, according to the sampling theorem the BCS has to simulate with twice the precision, i.e. with 1.45 mV. This applies for all conditions and for different balancing currents.

Even the most exact battery model is useless if the hardware cannot implement it precisely in reality. This is why comemso values precision so highly. A precision of 0.5 mV is our standard, and for end-of-line versions it is even better.

The flatness of the curve varies depending on the cell chemistry. However, examining the example charging curve shows that the flattest part is generally in the range between 20% and 80% SoC

## THE PRINCIPLE OF COULOMB CURRENT MEASUREMENT

Precise current measurements at a high frequency are always important for measuring balancing behavior, so comemso offers optional coulomb measurement with its battery cell simulators.

Each battery cell module has integrated

measurement electronics that can perform a measurement every 100  $\mu$ s. In a measurement interval, 500 values are added and converted to a physical value. This integrated value is then output via the communications bus. A measurement interval lasts 50 ms.

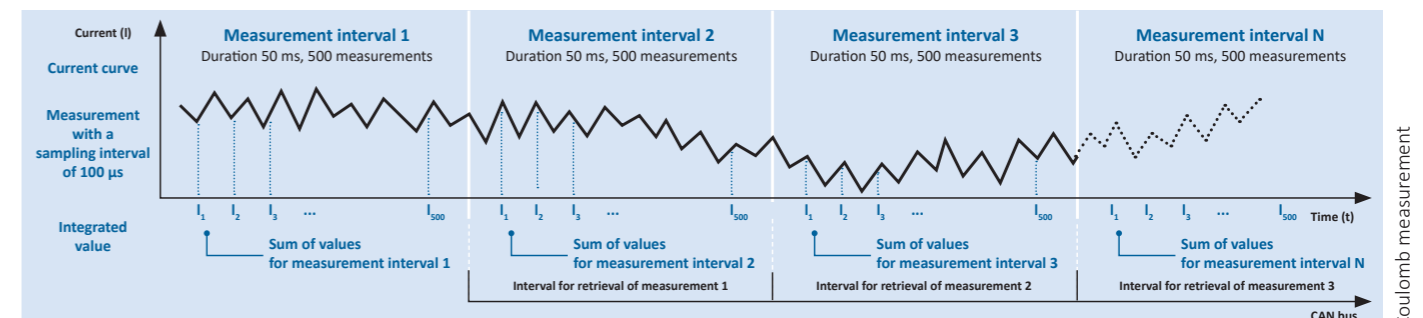

## THERMAL TEMPERATURE MONITORING

Battery cells have a narrow range of working temperatures. Both the lifespan and cycle stability of a battery cell and the functional safety of a battery depend largely on the battery cell staying within this range. If the temperature exceeds a critical limit, a thermal runaway will result; the temperature increases drastically within milliseconds and the energy stored in the battery is released abruptly. Extremely high temperatures lead to a fire that is very difficult to extinguish with the usual means. To minimize the danger of a thermal runaway, the BMS has to ensure the thermal stability of the energy storage

medium. This is done by temperature sensors (NTC/PTC) on the battery cells or the battery pack. For this reason, not only do today's battery cell simulators have to ensure precise measurements of current and voltage, they also have to simulate the temperature exactly. A galvanically isolated temperature sensor emulator for high-voltage NTC and PTC thermistors and simulators for short circuits and cable breaks affecting the sensors are also available. See also the "Design of BMS test bench" illustration on page 6. Other brochures on this topic are also available.

## CALIBRATION & FINE TUNING

As with any other sensor unit, the measurement accuracy of the battery cell simulator is subject to age-related variations. We recommend an annual recalibration to ensure that measurements retain maximum precision. There are three ways to do this:

BCS SmartCal measures all of an emulated battery cell's sensors automatically and can adjust them in the event of deviations. All three adjustment options include an ISO 9001 calibration report.

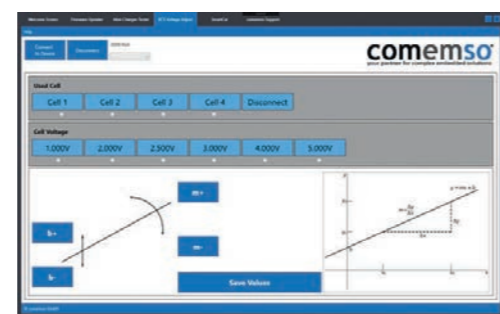

GUI recalibration

- Send the BCS modules to comemso for recalibration
- comemso service staff perform the recalibration on site
- For maximum flexibility, comemso also offers BCS SmartCal, a specially developed unit that you can use for in-house calibration

Starting with BCS Generation 8, fine tuning and recalibration of the voltage sensors is easy with the comemso Toolbox software. It can eliminate even the smallest of voltage inaccuracies. All that's needed is a USB connection to a PC and a basic CAN control system. No calibration report is created with manual recalibration.

## MATCHING HARDWARE AND SOFTWARE

For rapid-deployment test systems with low implementation costs, comemso battery cell simulators support globally established software solutions. They can be quickly integrated in existing software test environments. The diagram below summarizes the numerous connectivity options.

With a test automation system, sequential test runs can be performed without interruption around the clock. This saves an enormous amount of time and money while also increasing the usefulness and thus the quality of the test results.

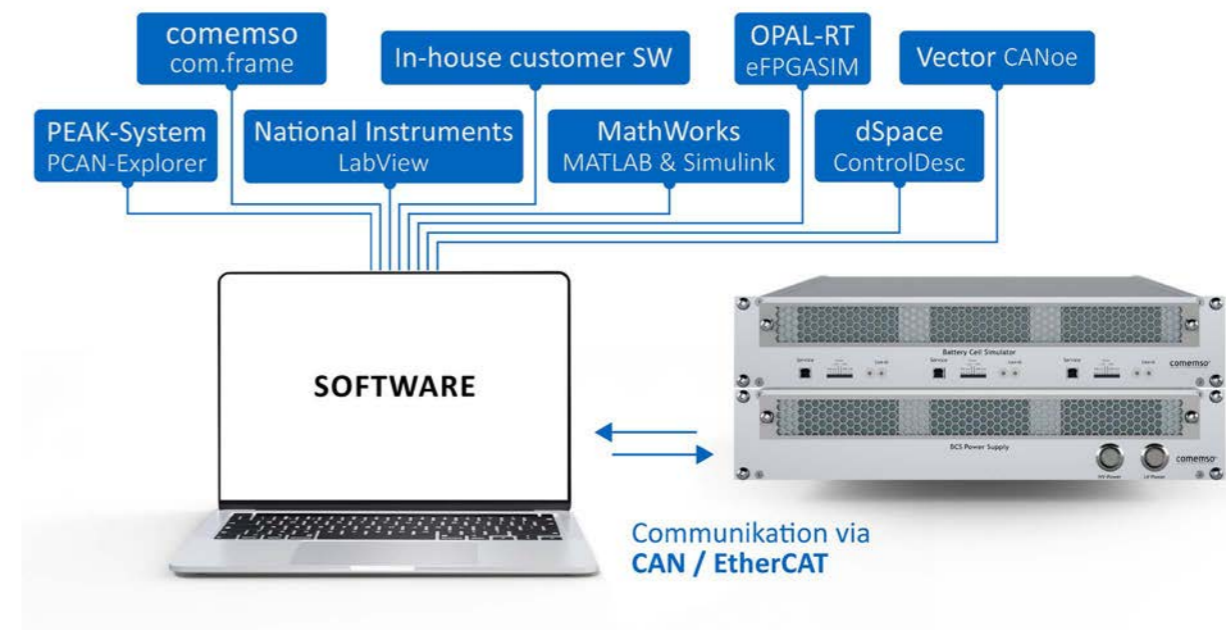

## CONNECTING WITH AUTOMATED TEST SYSTEMS

The comemso battery cell simulator has two interfaces for remote control. They are used for configuration and for reading out the measurements from all sensors, including the current voltage, current, error flags, hardware temperature, etc.

An unlimited number of cells can be addressed and read out via the CAN interface. In addition, an EtherCAT interface capable of cycle times in the  $\mu$ s range is available for high-speed applications with up to 120 cells. The available interfaces are open and documented, allowing you to use the test system of your choice. which enables complete integration in existing software environments (see illustration above).

These tools can be used to create scripts and test generators for the automation of tests and the creation of comprehensive test reports. MATLAB models can also be integrated for tests with dynamic cell behavior.



## MODELING BATTERIES

The state of charge is an important parameter for all battery-operated devices and plays a major role in energy storage systems. Its value is 100% when a battery is fully charged and decreases to 0% during discharging. Voltage measurements are generally used to determine the SoC value. With this method, a fully charged battery can be recognized by its higher voltage. However, the difference in voltage between the fully charged and discharged states is often only a few volts (V).

An alternative is to determine the SoC value by current integration (coulomb counting). In this method, the SoC value is derived from the coulomb value, which is found by observing the battery current over an integration interval. Both the current flowing into the battery and the current coming out of it are measured – in ampere-seconds (As) – and totaled (see p. 9).

Battery models have become an important tool in the development of battery-operated systems. They are utilized as soon as the use of real batteries is no longer possible due to safety considerations. With the aid of numerous adjustable parameters such as the current state of charge (SoC) or a cell's general state of health

(SoH), a virtual battery can emulate the behavior of a real battery. The comemso battery model works linearly and is specially adapted for the behavior of the BMS with changing values of SoC and SoH.

In addition to automated static tests and battery models based on MATLAB/Simulink for dynamic tests (see p. 11), starting with Generation 8 the comemso BCS also provides basic integrated battery models that can be individually configured for every cell. Models are stored directly in the BCS hardware and read out from it, so that dynamic basic battery behavior can be modeled economically even without MATLAB/Simulink.

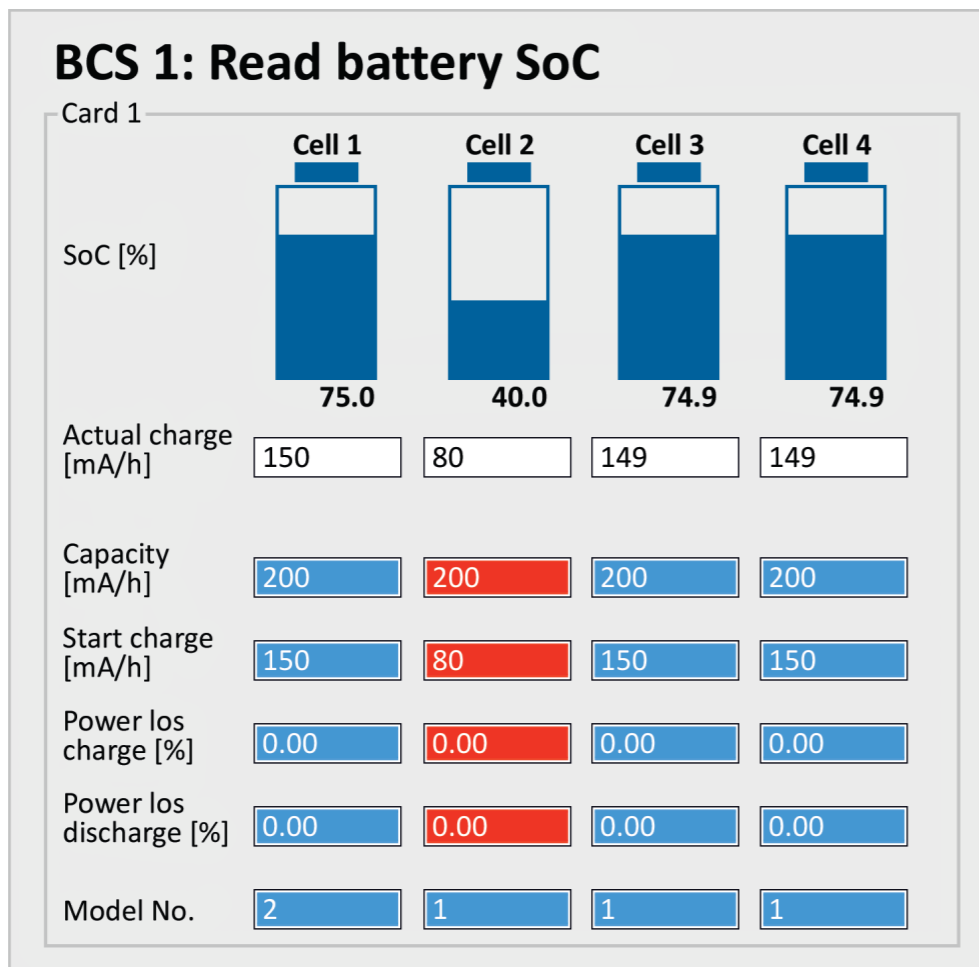

GUI configuration of battery behavior

## ELECTROMAGNETIC COMPATIBILITY

Test systems have to be robust and work reliably at all times. This also means they have to be immune to electromagnetic interference, and they must not adversely affect other (test) systems.

The comemso battery cell simulators meet the high standards of the directives on electromagnetic compatibility, as confirmed in frequent successful tests in our in-house EMC test chamber.



## FOR ALL CONDITIONS



It is not enough to ensure that a BMS will be robust under ideal conditions; it also has to work just as well under adverse climatic and environmental conditions. They always have to guarantee that all safety algorithms function correctly – in cold and heat, in sandy or salty conditions. In order to guarantee optimum performance over the entire lifetime of their electric vehicles, many tier 1 suppliers implement a climate chamber in their development and/or end-of-line tests.

Time is of the essence at the end of any assembly line, so comemso has developed a high-efficiency solution: a test system with a climate chamber that

can accommodate up to 12 BMSs for automated testing at higher and lower temperatures. End-of-line tests can then be performed more quickly and in rapid succession.

To speed up testing, a multiplexer (MUX) is used. It multiplexes the battery cells onto the desired test unit, then onto the next one and so on, without undersupplying the test units. Then the next test temperature is set and the tests are successively performed again on all of the test units. This saves a lot of time for the temperature changes.

## TAILORED TO YOUR NEEDS

With their modular design, comemso's battery cell simulators offer a wide range of tailored solutions in combination with standard components. Thanks to this flexibility, we can implement systems in different sizes to best meet the needs of our customers. We offer portable tabletop systems with 12 to 36 cells. These systems are ideal for chip manufacturers, start-ups or entry-level research. We also supply mid-sized systems with 24 to 60 cells that are of interest to the developers of battery management systems or active and passive balancing systems. And we can also provide systems with more than 204 cells in accordance with customer requirements. With all comemso systems, battery management systems can also be tested from the cell level to the pack level.

Regardless of their size, all of our systems can be configured as end-of-line variants for continuous operation in series validation, in test and certification labs, and for final inspection at vehicle manufacturers.

We will be happy to advise you personally and work out a perfect solution that meets your requirements and your budget. To help us do so, please fill out the specification sheet on the following pages. Benefit from our years of experience in electromobility! Our technical sales staff looks forward to receiving your inquiry.



**Portable**  
12 to 36 cells

**Mid-size**  
24 to 60 cells

**Full-size**  
> 204 cells

## INTEGRATED INTERFACE TESTING

The rapid progress in electromobility compared with conventional combustion engine vehicles has led to new challenges. The new focus is on electronics and software, which have to take on many more monitoring tasks.

Essentially, two control units are involved: the battery management system (BMS) and the electric vehicle charge controller (EVCC), which is part of the on-board charger (OBC). As described on the preceding pages, the BMS is responsible for monitoring and, if necessary, adjusting the vehicle battery. The EVCC controls the communication and the current flow during charging between the electric vehicle and the charging station. As the link between the BMS and the charging station, the EVCC constantly measures the vehicle battery's state of charge (SoC) during charging. This applies equally for both AC and DC. If the EVCC detects that the vehicle battery is fully charged or that an unexpected error has occurred, it instantly sends

an alert to the charging station to interrupt the charging process and prevent damage to the vehicle battery.

This means it is extremely important to test all relevant parameters between the BMS and the EVCC in the lab with an integrated test bench early in the development phase to ensure that potential sources of error are detected safely, automatically and reproducibly so that future risks can be avoided.

Years of practical experience and insights from extensive electrical fault simulations have made comemso's integrated test bench a high-precision hardware-in-the-loop system. It can be used to perform tests and analyses of the communication between the BMS and the EVCC/OBC that meet the demanding standards and complex requirements of OEMs and tier 1 suppliers.

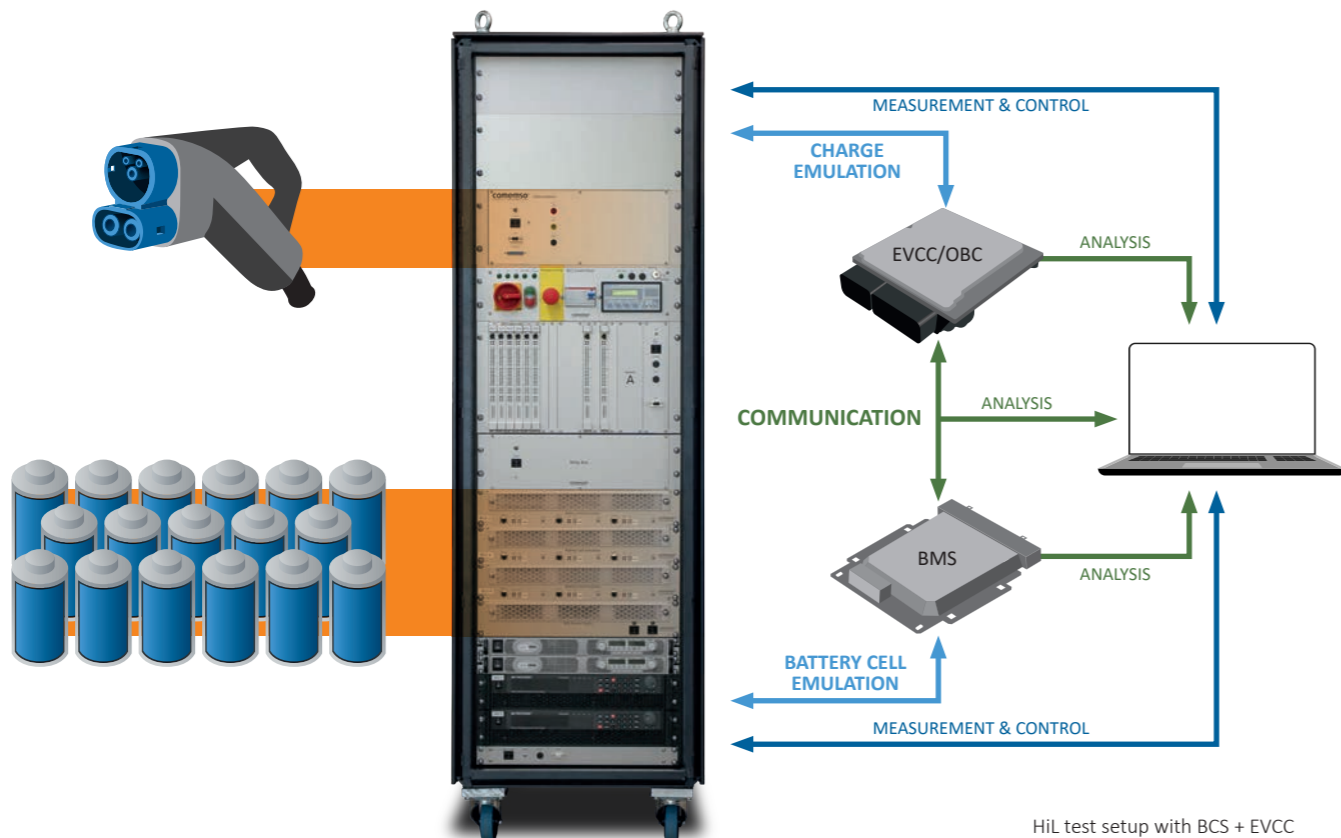

HiL test setup with BCS + EVCC

## SPECIFICATION SHEET FOR BATTERY CELL SIMULATORS

So that we can provide you with the most accurate quote possible, please answer the following questions about your technical requirements.

Company: \_\_\_\_\_ Department: \_\_\_\_\_

Address: \_\_\_\_\_ Postal code and city: \_\_\_\_\_

Country: \_\_\_\_\_

### Technical contact

Name: \_\_\_\_\_ Email: \_\_\_\_\_ Phone: \_\_\_\_\_

### Procurement contact

Name: \_\_\_\_\_ Email: \_\_\_\_\_ Phone: \_\_\_\_\_

Industry:  EV manufacturer  BMS manufacturer  Chip producer  Integrator  Other: \_\_\_\_\_

Activity:  Research  Development  Production / End-of-line (EOL)

### 1. Cell simulation/emulation

a) How many cells do you want to simulate? \_\_\_\_\_ cells

b) What balancing current is needed for active balancing?

As source: \_\_\_\_\_ A; As load: \_\_\_\_\_ A

c) Extras:

Coulomb measurement   $\mu$ A measurement  Fault simulation (short circuit, reversed polarity)

Enhanced fault simulation (measuring leads to BMS)

d) Connection to test unit:

Cable set (open wire)

Cable set + cascading box

Break-out box (lower precision)

### 2. Temperature simulation

How many temperature channels do you want to simulate? \_\_\_\_\_ channels

Optional fault simulation (short circuit, cable break)

### 3. Insulation resistance

Emulation of insulation resistance for \_\_\_\_\_ channels

### 4. BMS current measurement

Shunt simulation (-150 mV to +150 mV)

Current sensor emulation (-6 V to +6 V)

Real current sensor; required current: \_\_\_\_\_ A

### 5. Housing

Rack system

Tabletop system

Integration in customer's rack/tabletop system

Comments: \_\_\_\_\_

Continue on other side.



Please scan or photograph the completed form and send it to sales@comemso.com. Or you can download a fillable PDF file at www.comemso.com/BCS\_Specification\_Sheet.pdf.



**6. Power supply (test bench)**

a) Voltage/current available in lab:

Supply voltage: \_\_\_\_\_ V

Current: \_\_\_\_\_ A

- 1-phase       3-phase       with N

Other: \_\_\_\_\_

b) Emergency stop switch

- Yes       No

c) Insulation monitoring

- Yes       No

**7. Control and communication software**

a) Software in use:

- PEAK PCAN       Vector CANoe       NI LabVIEW

- MATLAB tool       dSpace ControlDesk

Other: \_\_\_\_\_

b) Will you need a starter project?

- for PEAK PCAN       for Vector CANoe       for NI LabVIEW

- for other MATLAB tools

for the following software: \_\_\_\_\_

c) Additional interfaces (CAN is included as standard):

- EtherCAT

Other: \_\_\_\_\_

**8. Integrated test bench**

Is an integrated test bench planned?

- Yes, with EVCC       No

Yes, other: \_\_\_\_\_

**9. Project information**

a) When is the project scheduled to start? \_\_\_\_\_

b) What is your project budget? €/ \$

- < 50,000       50,000 to 100,000       100,000 to 200,000       > 200,000

c) Is there a requirements specification? (If yes, please specify.)

- Yes       No

e) Is a third party or end customer involved in this project?

- Yes       No

If yes, who is the third party or end customer? \_\_\_\_\_

**10. Is an expansion planned in the future?**

- Yes, see the system design. Ultimately \_\_\_\_\_ cells are planned.

- No

**11. Other requirements**

\_\_\_\_\_

\_\_\_\_\_

\_\_\_\_\_

\_\_\_\_\_

\_\_\_\_\_

# COMEMSO BATTERY CELL SIMULATOR EXAMPLE WITH 24 VIRTUAL BATTERY CELLS AND SEPARATE SIDE UNIT





comemso electronics GmbH  
Karlsbader Str. 13  
D - 73760 Ostfildern



+49 711 982 98 - 200



sales@comemso.com



www.comemso.com

SUPPORTED AND TESTABLE STANDARDS



MEMBER OF



FUNDED BY

